

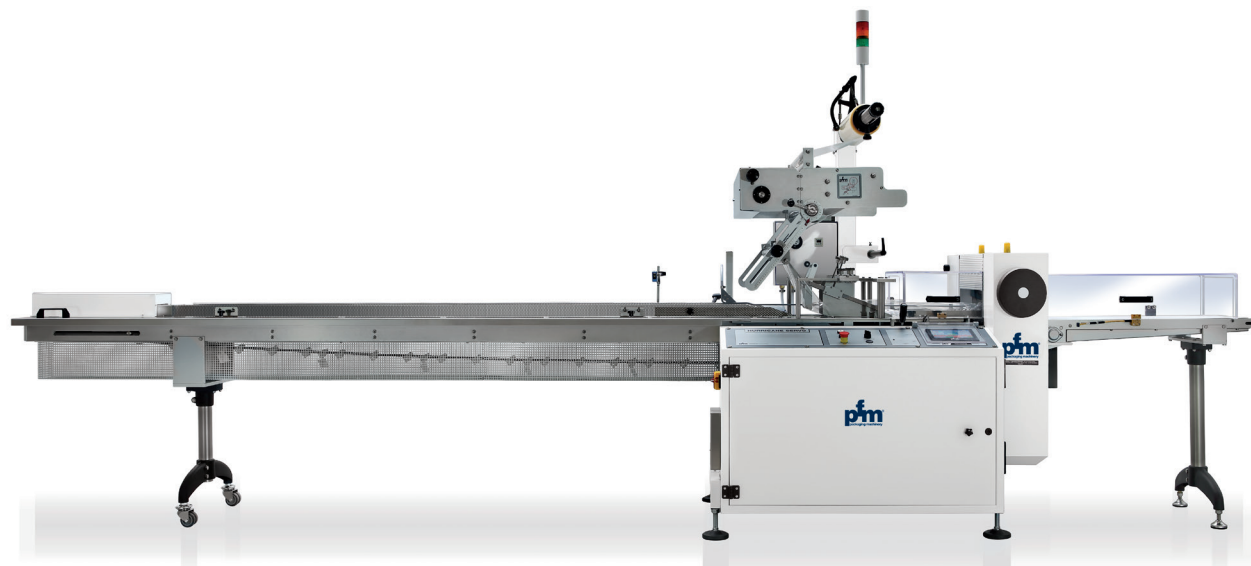

HURRICANE SERVO

Horizontal Flowwrap Machine



Ph: 1800-801243 www.emrich.com.au



HURRICANE SERVO:

Horizontal Flowwrap Machine

The horizontal flow wrapper model Hurricane Servo is the PFM entry level model among the horizontal flow wrappers. It's a machine with a simple construction, it's an extremely flexible wrapper and is able to handle a wide variety of products. The Servo version, electronically controlled, is supplied with brushless motors to drive the infeed conveyor, the fin seal rollers and crimpers; touch screen panel, adjustable forming box and self centering reel holder.





BENEFITS: HURRICANE SERVO

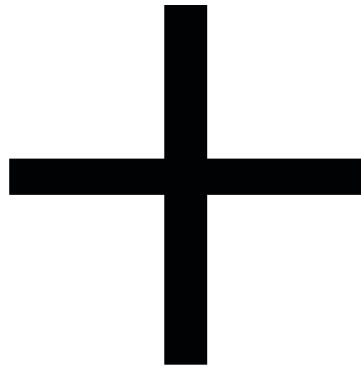

Perfect Packages

The special design of the forming box, optimum calender and rollers to aid film transfer combine to produce a machine that wraps products perfectly, producing neat, crease free packs.

Flexibility

The PFM Hurricane Servo can wrap a wide range of regularly shaped, solid products from the food, stationery, chemical and pharmaceutical sectors. It is not necessary to change any mechanical parts in order to adjust the set-up, this is done by using two hand-wheels which carry out immediate adjustments to the pack length and the speed of the sealing crimpers.

Materials

The PFM Hurricane Servo can be configured to utilize a wide range of heat-sealable materials including laminated or bonded polypropylene, polyethylene (Poly version), micro-perforated and also shrink-wrap materials.



FEATURES:

Technical Characteristics

- Carbon steel frame, standard colour white RAL 9010.
- 3 sets of fin seal wheels for longitudinal sealing: the first pulls the wrapping material, the second seals the material and the third folds the flap.
- Forming box with adjustable height and width for different size products.
- Self centering reel holder with brake.
- 2 m long infeed conveyor with quick release and interchangeable pushers.
- 1000 mm long motorized discharge conveyor.
- All product contact parts are built in AISI 304 stainless steel.



Available Versions

- Extra wide version for 700 mm reel width.
- Left hand version (products flow from right to left).
- Stainless steel version.
- Poly version.
- Shrink version.

Main Options

- Date coder.
- Photocell for print registration.
- Double reel holder.
- Power feed roll.
- Gusset tucking.
- Additional meters on infeed conveyor.
- Pre-heating bars.
- Two up sealing crimpers to be used with small products and high speed.
- Teleservice kit.





PACK SAMPLES: HURRICANE SERVO



TECHNICAL DATA:

	Hurricane Servo	Hurricane Servo EW
Pack length (mm):	min 40, max 500 *	min 40, max 500 *
Pack width (mm):	min 5, max 230 *	min 5, max 320 *
Pack height (mm):	up to 100 * (Standard version) 140 * (Special version)	up to 120 *(Standard version) 140 * (Special version)
Reel width (mm):	max 600	max 700
Reel diameter (mm):	max 350	max 350
Width of sealing crimper jaws (mm):	250	350
N° of up sealing crimpers jaws:	1 - 2	1 - 2
Mechanical speed (cycles/min):	up to 100 *	up to 100 *
Weight (Kg):	310	350
Power supply:	380V 3ph.+N+G, 50Hz	380V 3ph.+N+G, 50Hz
Power consumption (Kw):	8	8

* The three maximum sizes cannot be tolerated simultaneously.

PFM reserve the right to make modifications without prior notice.

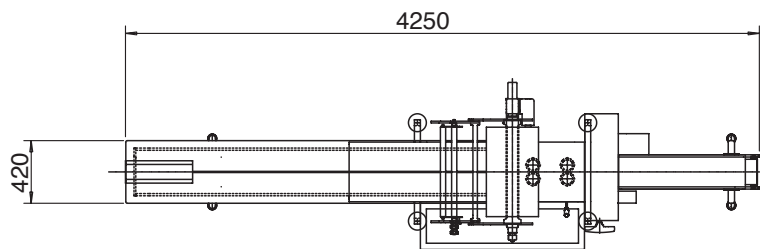

Hurricane Servo

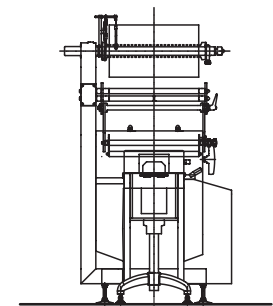
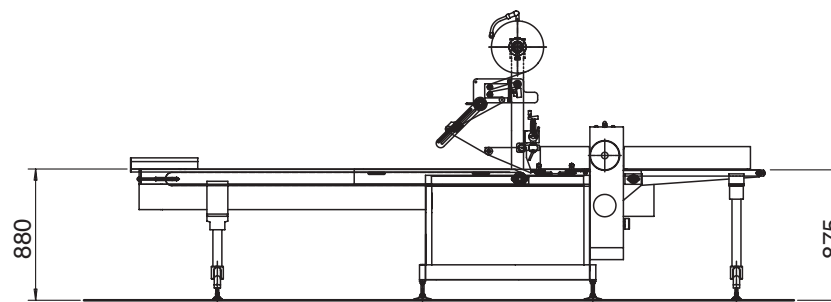

TECH AREA ACCESS
ACCESSO AREA TECNICA

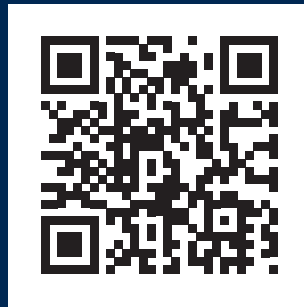

www.pfm.it/hurricane-servo

